

PC-01 Magnetic panel catch fixing instructions

NOTE: DO **NOT** REMOVE CLEAR PAD BETWEEN BOTH PARTS

OPTION A

1. Position the swing door at the point you wish it to stop. Allow for Furniture & some tolerance
2. Hold the fully assembled panel catch between your fingers. (Do not unscrew the back plates yet)
3. Offer up the full assembly panel catch and mark the position for fixing on one panel only.
4. Unscrew one back plate and fix with choice of fixings provided in line with the mark. Ensure the anti rotation screw is toward the swing/pass door hinge.
5. Screw in and tighten the 3mm pointed anti rotation grub screw. For hard material (ie Steel or aluminium) let the screw make a mark then remove screw and drill a small hole 1.5-2mm hole . Re-fix grub screw)
6. Screw on the outer sleeve complete with the opposite catch still attached. Ensure anti rotation screw is nearest the swing door hinge
7. Carefully position the opposite panel up to the catch
8. Mark the perfect position for fixing on the opposite panel
9. Repeat steps 4 & 5
10. Screw on the outer sleeve
11. Show end user how to correctly locate/release the door. Explain the catch is not designed for hard impact or fixed retention.

OPTION B

1. Position the swing door at a point you wish it to stop. Allow for furniture & some tolerance.
2. Find the point between the two panels at the top or bottom which measures 25mm and mark it
3. Unscrew one back plate and fix with choice of fixings provided in line with the mark. Ensure the anti rotation screw is nearest the swing/passdoor hinge for best angle
4. Screw in and tighten the 3mm pointed anti rotation grub screw. (For hard material IE: Steel/aluminium let the screw make a mark then remove screw and drill a small hole 1.5-2mm hole . Re-fix grub screw)
5. Screw on the outer sleeve complete with the opposite catch still attached. Ensure anti rotation screw is nearest the swing door hinge
6. Carefully position the opposite panel up to the catch
7. Mark the perfect position for fixing on the opposite panel
8. Repeat steps 3 & 4
9. Screw on the outer sleeve
10. Show end user how to correctly locate/release the door. Explain the door is not designed either for impact or for fixed retention.

To be read in conjunction with drawing overleaf

MAGNETIC PANEL CATCH DETAIL

PC-01

PARTS LIST

1. Fully assembled panel catch
2. Rivnut M5 x 12mm 2 off
3. M5 X 16 csk machine screw 2 off
4. No10 x 25 csk. self tapping screw 2 off
5. M5 pointed grub screw 2 off

NOTE: 7.5mm-7.6mm drill size required for rivnut.

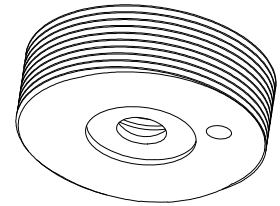
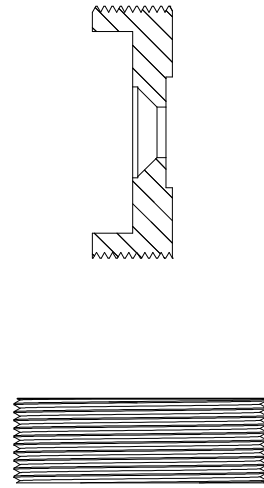
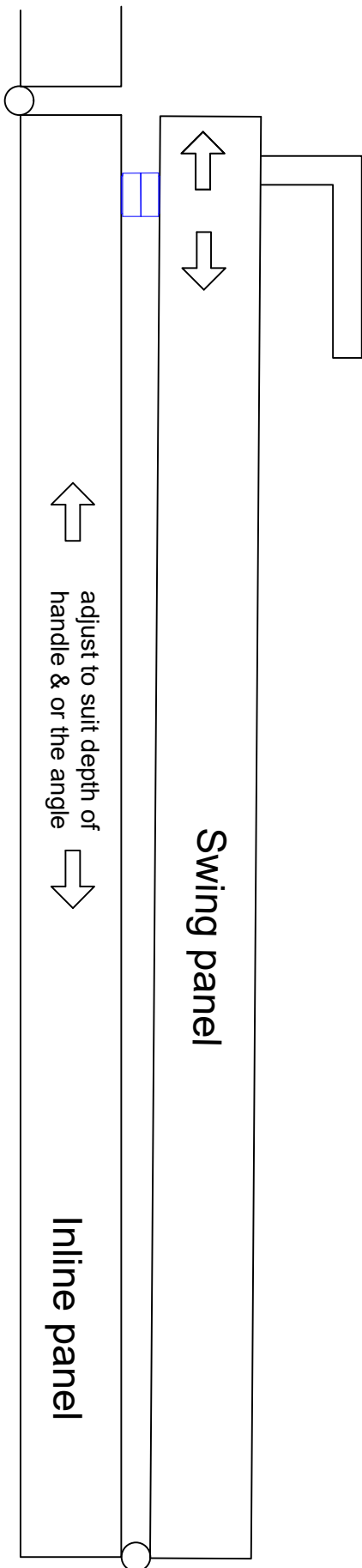

Three Quarter Below View

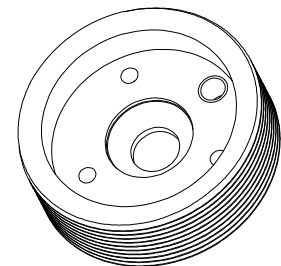
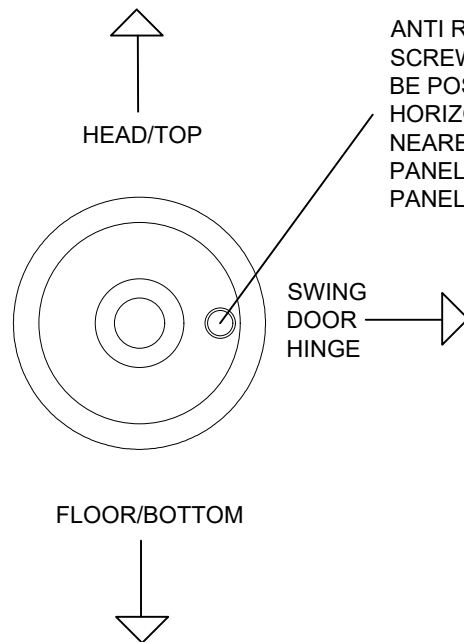

Three Quarter Above View

